

WATEROUS PACER WB-67

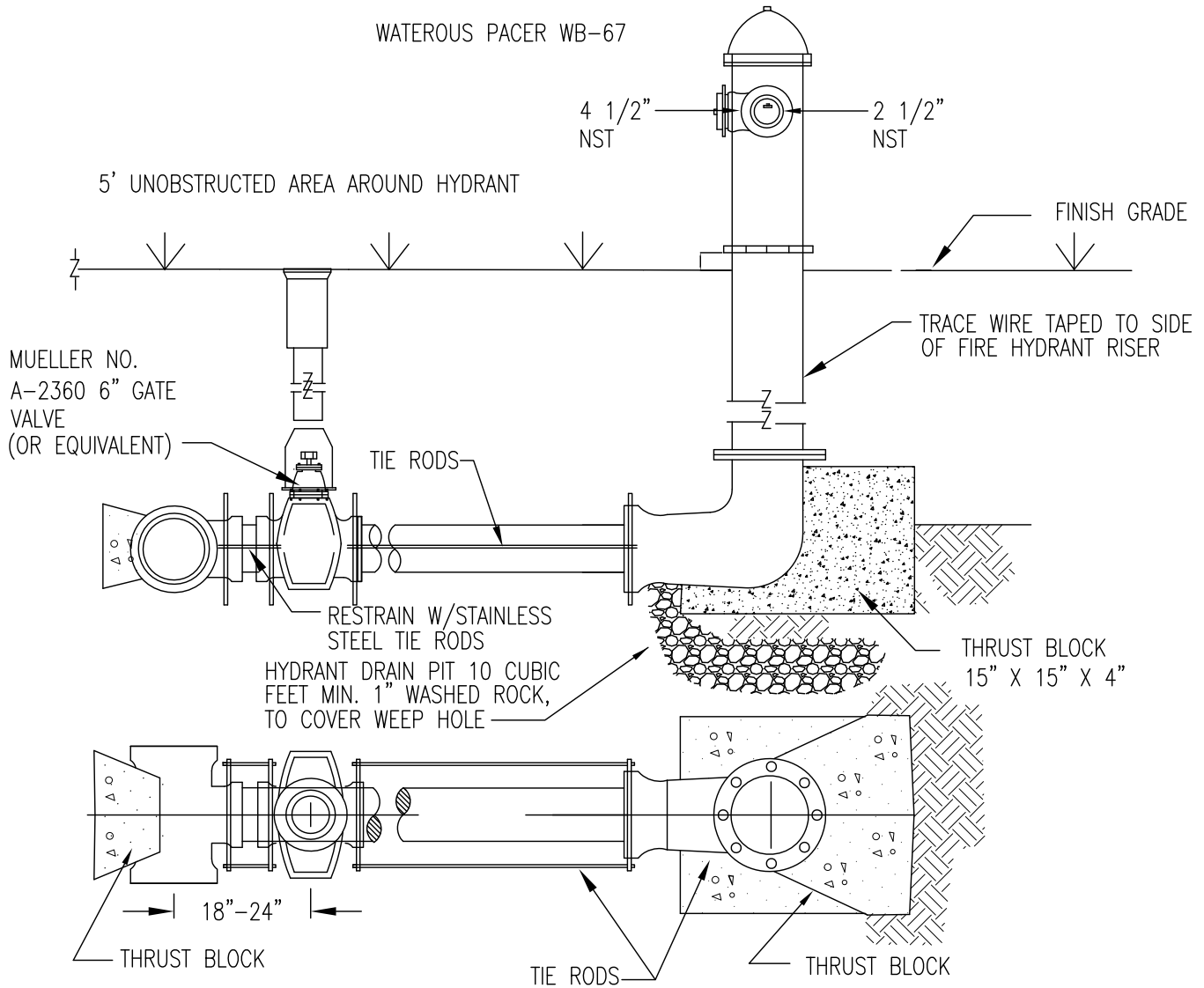

NOTES:

1. WRAP ALL FITTINGS WITH 8 MIL. POLYETHYLENE IN ACCORDANCE WITH AWWA C105-72.
2. THE 6" PVC PIPE CONNECTION FROM THE WATER MAIN TO THE HYDRANT WILL BE DIRECT. VERTICAL OR HORIZONTAL OFFSET USING ELLS SHALL NOT BE ALLOWED.
3. INSTALL HYDRANT EXTENSIONS AS REQUIRED TO RAISE TO GRADE



P.O. BOX 457  
 601 METZ DRIVE  
 GILLETTE, WY 82717  
 (307) 682-8936

WRIGHT WATER & SEWER DISTRICT  
 FIRE HYDRANT DETAIL